

\* Inlocuieste desen nr. 00078

Obs. - Cond. generale conform SF 690/1

NAME	DATE	REVISIONS	MOLD No:	550.00.089		A4		YIOULA Glassworks Stirom Romania	
			FINISH No:	550.00.089-1					
			PROCESS	PB	MACHINE	DG 5 1/2"	BOTTLE:	DONAU 220 ml	
			TYPE	NRB	TIP ANGLE	-			
			CAP. BRIMF.	220±9ml	REF MOLD:	-		CAT.No & DWG No:	
			CAP. FILLPT.	-	FINISH:	63 REGULAR		00532	
			FILL LINE	-	DRAWN	GHENGEAUA F.			
S.F.	01.06.10	Modificat cartus	WEIGHT	~140 g	CHECKED	DIMA L.		DATE	09.01.2008
S.F.	17.09.08	Modificat toleranta	COLOR	FLINT	CONFIRMED	DIMA L.		SHEET: 1/1	SCALE: 1:1

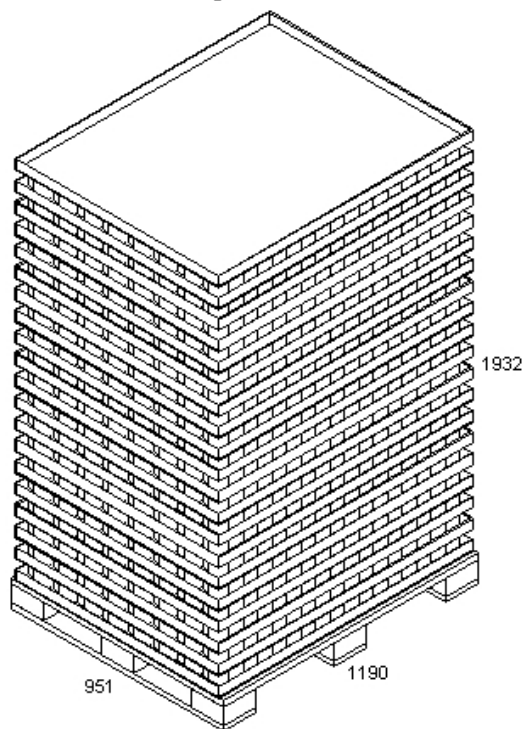
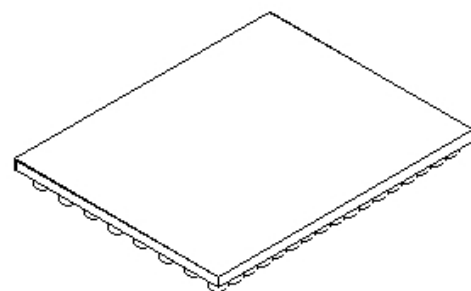
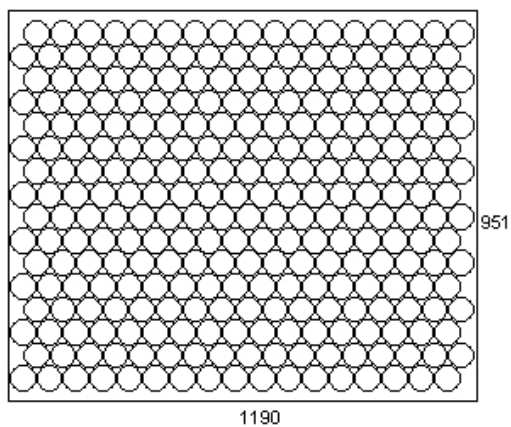

Notes: Asezare pe tava: 17x16 = 272 buc, 20 rinduri, 5440 buc/palet, dimens. tava carton: 1200x1000x70 mm; deasupra placa carton: 1200x1000 mm, H palet = 1.94 m, G palet = 804 kg (masa = 140 g), folie 2800 mm pliu mare