

D

C

B

A

8

8

7

7

6

6

5

5

4

4

3

3

2

2

1

1

D

C

B

A

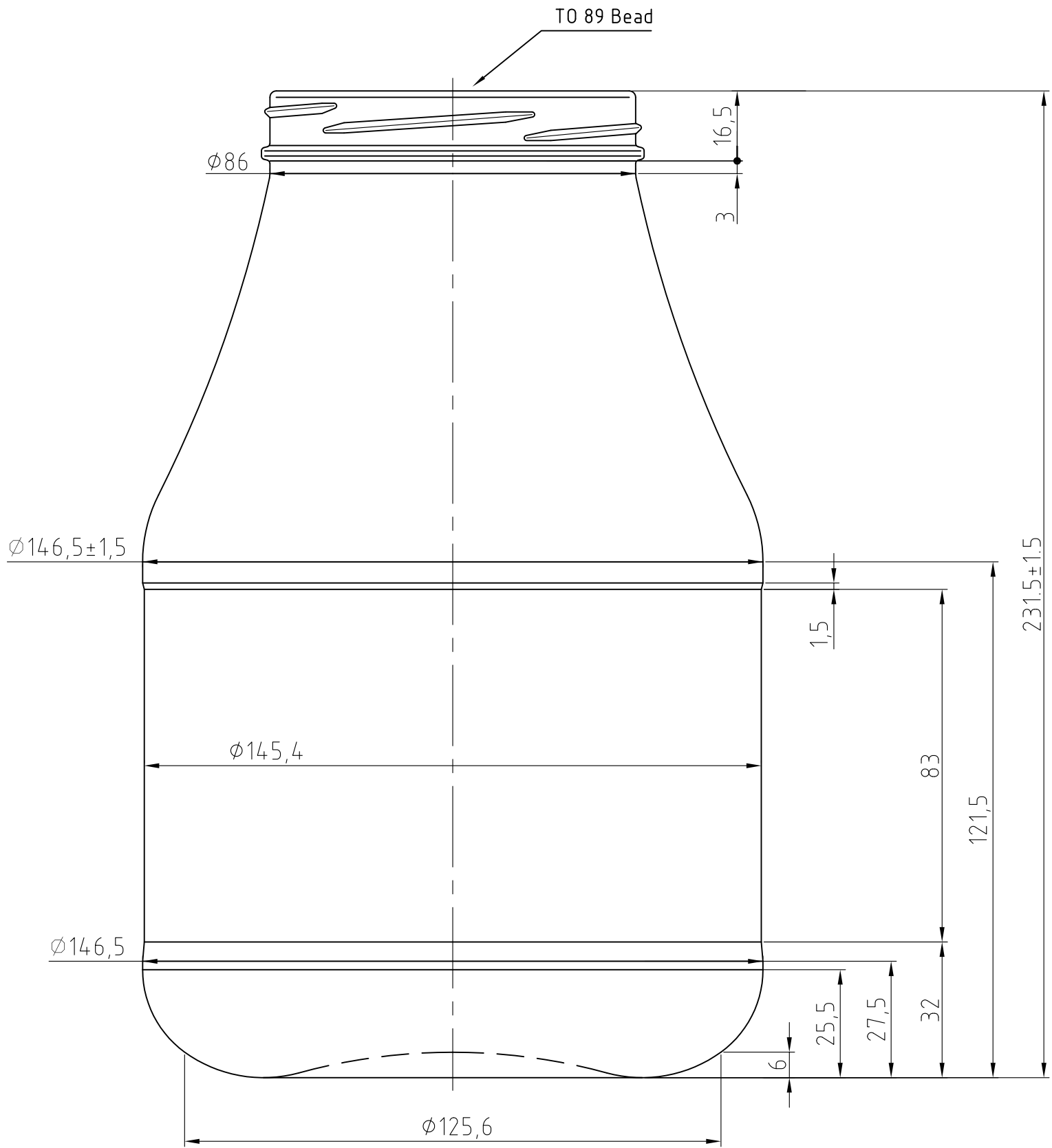
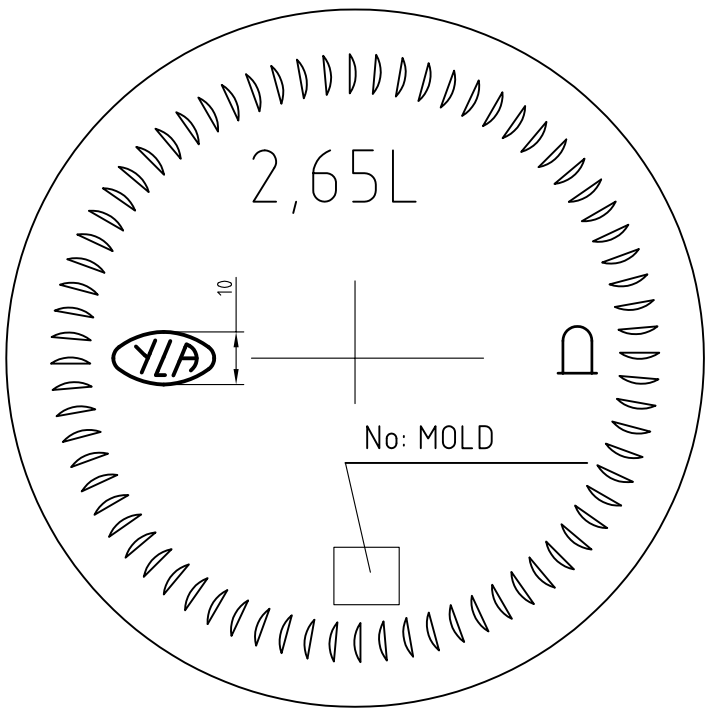

NAME	DATE	REVISIONS	MOLD NO.			A3	DRUJBA Glassworks S.A. A Member of Yioula Group	
A.A	08/2006	New height - 231.5mm	FINISH	FIN 064			BOTTLE	
		New weight - 980gr	CAP. BRIMF.	2650±50ml	MACHINE	SG 4 1/4"	265cl JAR " S "	
			CAP. FILLPT.		DATE	17/08/2006	CAT.No & DWG No	
			FILL LINE		DRAWN	Angelov	8237064	
			WEIGHT	980±20gr	CHECKED		SHEET: 1/1 SCALE: 1:1	
			COLOR		CONFIRMED	D.O'Connor		



JARS

265cl S TO89 c8237046-pad 8r

Date Printed : 6/7/2010

Last Saved : 6/7/2010

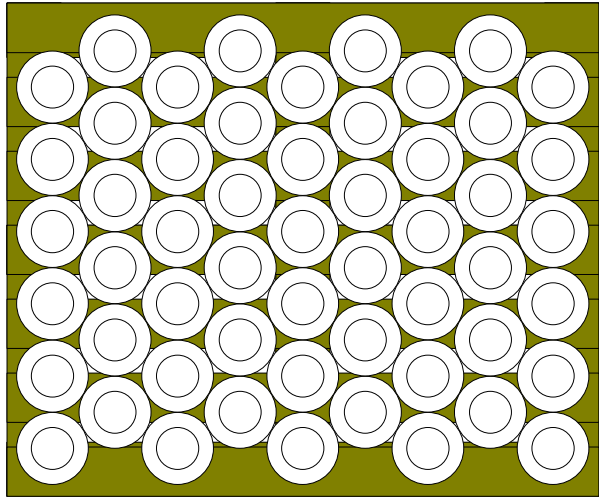

1200.0

1000.0

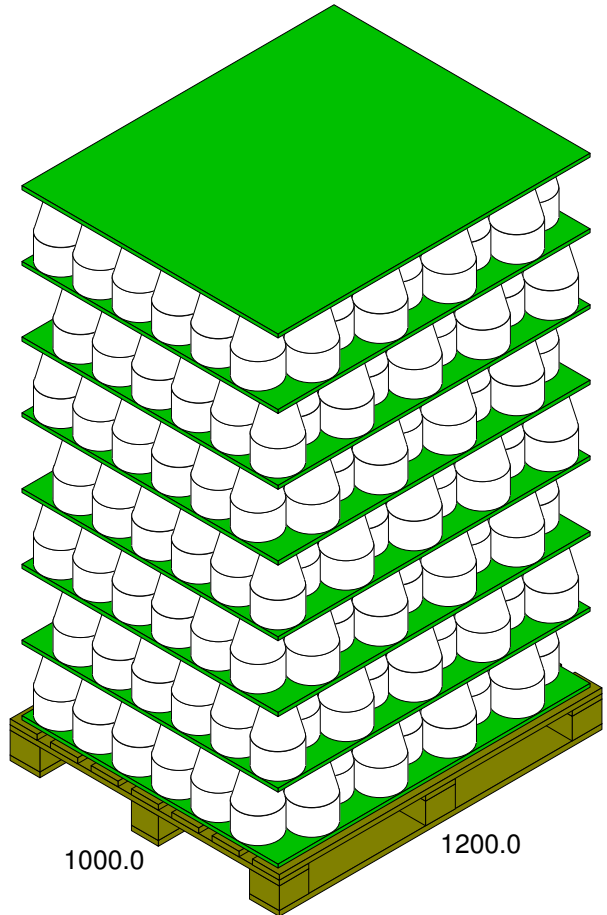
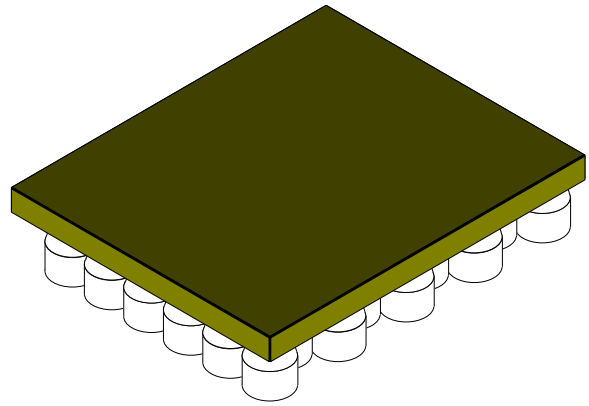

2001.2

DRUJBA PALLET 09 1200.0x1000.0x134.0

	Bottle (ID)	Bottle (OD)	UnitLoad (Incl. Pal)
Ln:	146.50 mm	146.50 mm	1200.0 mm
Wd:	146.50 mm	146.50 mm	1000.0 mm
Ht:	231.50 mm	231.50 mm	2001.2 mm
Gr:		980.00 g	445.4 kg
Cube:	2.99 l	2.99 l	2.4 m3
		Height Vert	
Prod.Vol:	0.00 l		0.00 m3
Bottle:			432
Area Efficiency:			96.6 %
Cubic Efficiency:			54.7 %
Prod.Eff:	0.0 %	0.0 %	0.0 %
Cases per layer:			54
Layers/load:			8
Pattern:			Staggered
Max UL High:			4
Clamp Direction:			N/A

Notes: THE WOODEN PALLET IN USE IS SPECIALLY FUMIGATED. STANDARD PALLET