

DETAIL A  
(SCALE 5:1)

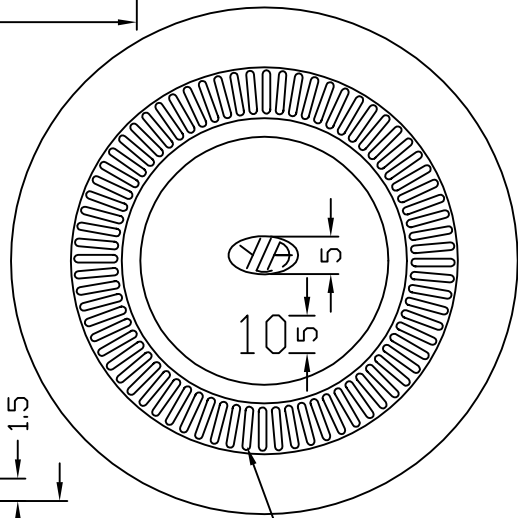

Bar stipple

YIOULA S.A. GLASSWORKS		Mold No.	22273	Capacity	212( $\pm 3.5$ )cc
		Bottle	JAR 0.2L	Fill line	
DWG No	22273/1	Customer		Weight	150( $\pm 7$ )gr
				Finish	63 T.O. FD138
Date: 12/04/02	Scale: 1:1	Machine	DG 4 1/4"	Color	FLINT

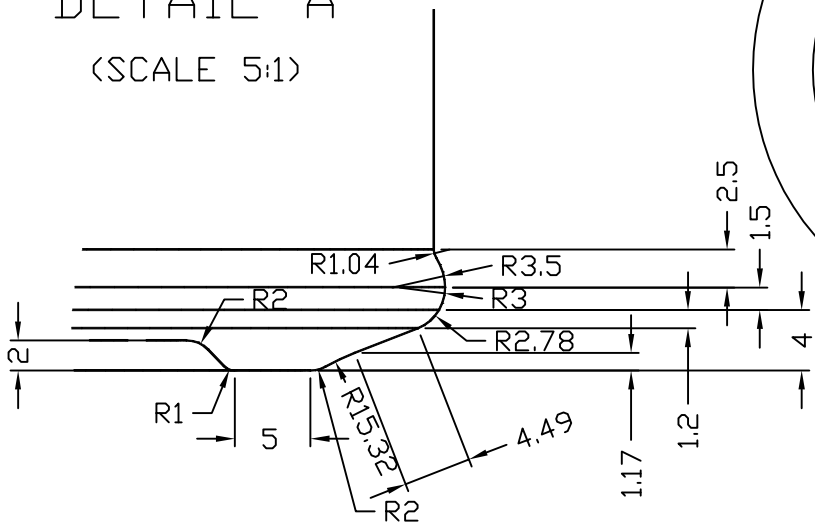

Jar 200ml \_ 63TO\_(22273)

Date Printed : 9/3/2011

Yla Code: 22273

Last Saved : 9/3/2011

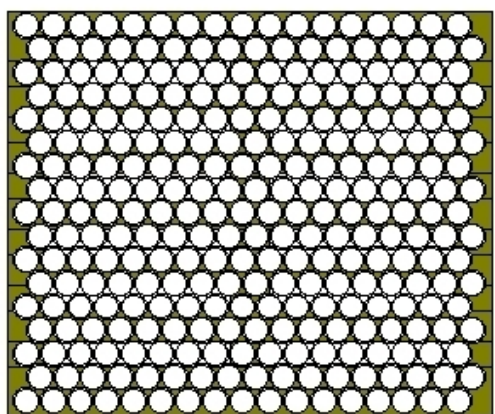

1000.0

1200.0

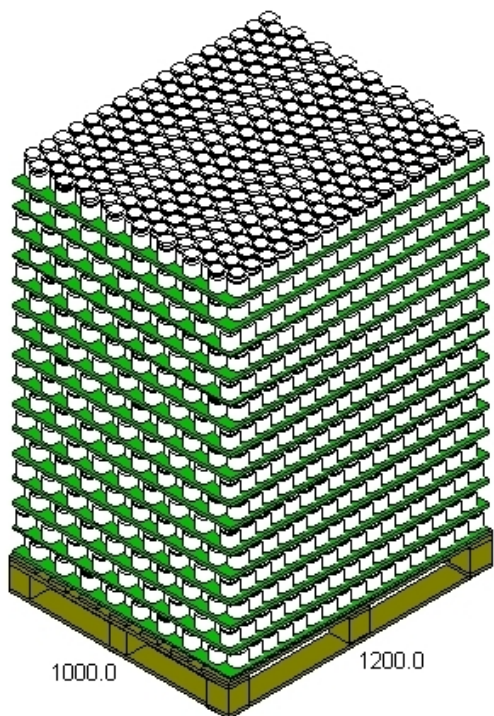

1612.7

1000.0

1200.0

HP 1200x1000 1200.0x1000.0x144.0

	Bottle (ID)	Bottle (OD)	UnitLoad (Incl. Pal)
Ln:	67.00 mm	67.00 mm	1200.0 mm
Wd:	67.00 mm	67.00 mm	1000.0 mm
Ht:	84.90 mm	84.90 mm	1612.7 mm
Gr:		150.00 g	761.9 kg
Cube:	0.29 l	0.29 l	1.9 m3
		Height Vert	
Prod.Vol:	0.20 l		1.0 m3
Bottle:			4913
Area Efficiency:			108.1 %
Cubic Efficiency:			81.9 %
Prod.Eff:	68.7 %	68.7 %	50.8 %
Cases per layer:			289
Layers/load:			17
Pattern:			Staggered
Max UL High:			0
Clamp Direction:			N/A

Notes: Wooden pallet(1200x1000x145)-Jars per layer:(17X17)=289-No of layers:17-Jars per pallet:4913- Flat plastic sheet placed to wooden pallet , underneath bottom plastic pad to protect against any moisture.PLASTIC PADS