

D C B A

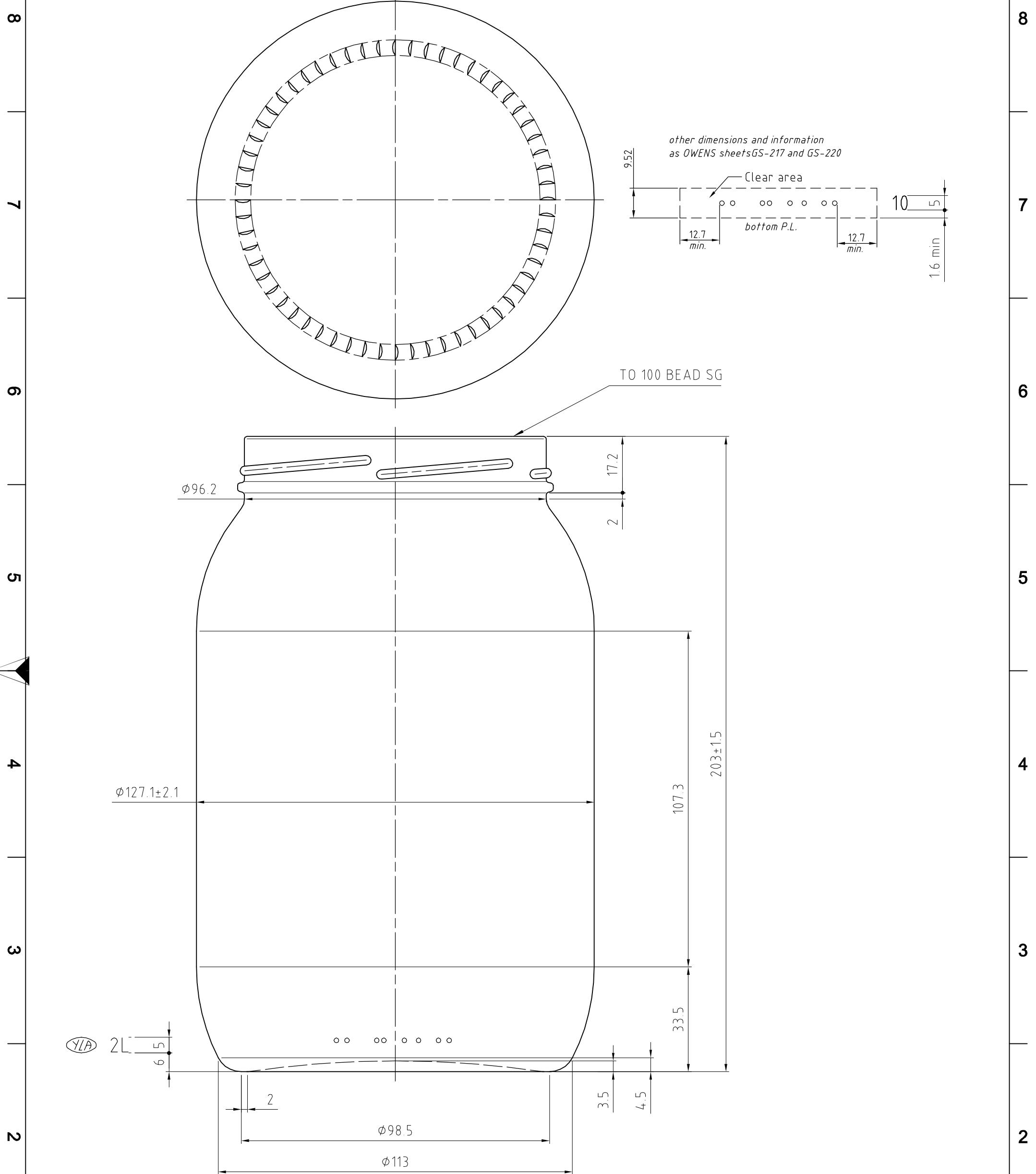

other dimensions and information as OWENS sheets GS-217 and GS-220

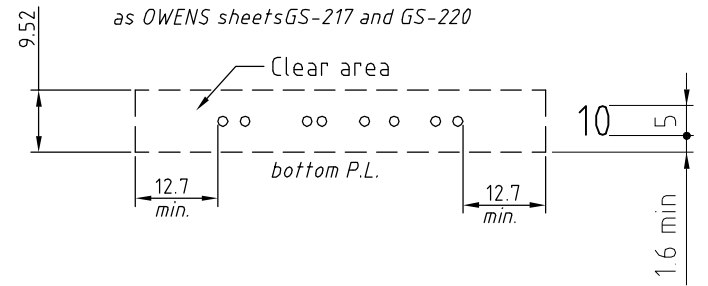

TO 100 BEAD SG

φ96.2

φ127.1±2.1

φ98.5

φ113

17.2  
2

203±1.5

107.3

33.5

2  
6

2

3.5

4.5

On the base of drawing 22272-YIOULA

NAME	DATE	REVISIONS	MOLD NO.			A3	DRUJBA Glassworks S.A. A Member of Yioula Group	
MD	04/09	Weight was 800gr.	FINISH	FIN 065			BOTTLE	
			CAP. BRIMF.	2015±17.5ml	MACHINE	SG 4 1/4"	JAR	
			CAP. FILLPT.		DATE	23/04/2009	CAT.No & DWG No	
			FILL LINE		DRAWN	Dimov	8466065	
			WEIGHT	828±29gr	CHECKED	Angelov	SHEET: 1/1	
			COLOR	FLINT	CONFIRMED		SCALE: 1:1	

D C B A

8  
7  
6  
5  
4  
3  
2  
1

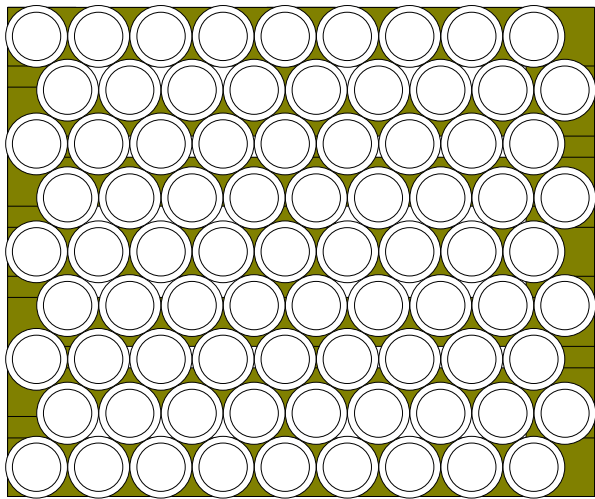

1007.7

1207.5

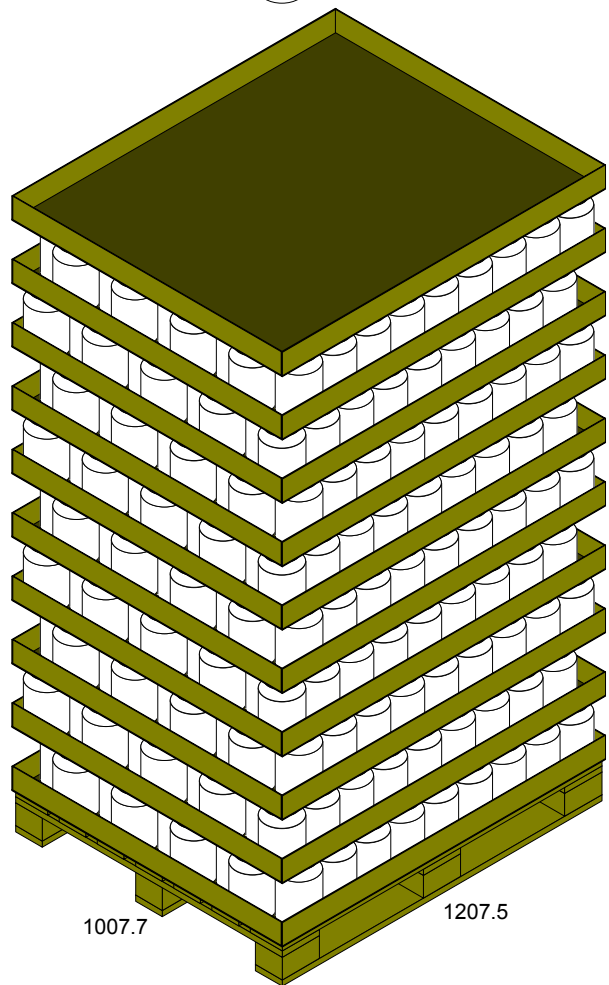
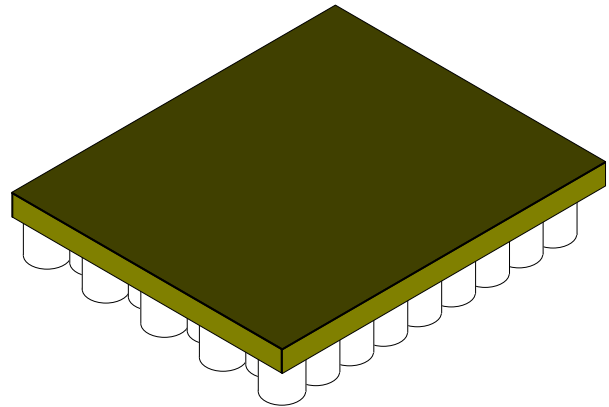

2219.9

1007.7

1207.5

**DRUJBA PALLET 09 1200.0x1000.0x134.0**

	Bottle (ID)	Bottle (OD)	UnitLoad (Incl. Pal)
Ln:	127.10 mm	127.10 mm	1207.5 mm
Wd:	127.10 mm	127.10 mm	1007.7 mm
Ht:	203.00 mm	203.00 mm	2219.9 mm
Net:		828.00 g	670.680 kg
Grs:		0.00 g	22.000 kg
Cube:	2.980 l	3.0 l	2.7010 m3

Height Vert

Bottle:	810
Area Efficiency:	109.04 %
Cubic Efficiency:	95.05 %
Cases per layer:	81
Layers/load:	10
Pattern:	Staggered

Notes: THE WOODEN PALLET IN USE IS SPECIALLY FUMIGATED