

Obs. - Cond. generale conform SF 675/1

\* Conform desen 1.160-C16-100

NAME	DATE	REVISIONS	MOLD No:	220.00.650		A4		YOULA Glassworks	
			FINISH No:	220.00.070				Stirom Romania	
			PROCESS	BB	MACHINE	DG 4 1/4"	BOTTLE:		
			TYPE	NRB	TIP ANGLE	-	MARASCA 0.1L		
			CAP. BRIMF.	111±3 ml	REF MOLD:	-	CAT.No & DWG No:		
			CAP. FILLPT.	100±3 ml	FINISH:	24 STD	00683		
			FILL LINE	~45 mm	DRAWN	DIMA L.			
			WEIGHT	~120 g	CHECKED	GHENGEAUA F.	DATE	26.11.2010	
			COLOR	FLINT/UVAG	CONFIRMED	CONSTANTINESCU S.	SHEET: 1/1	SCALE: 1:1	

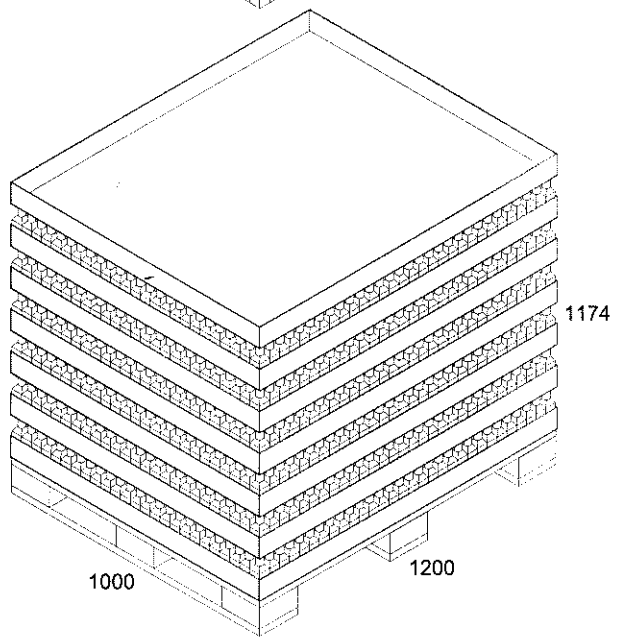
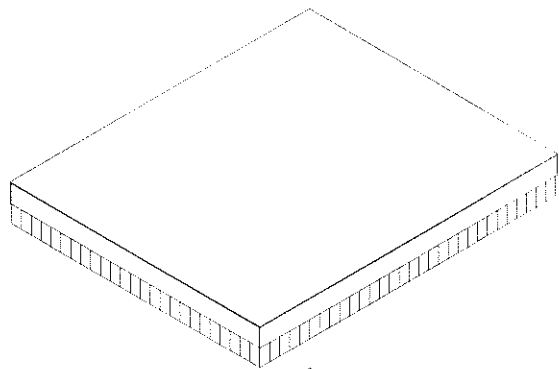
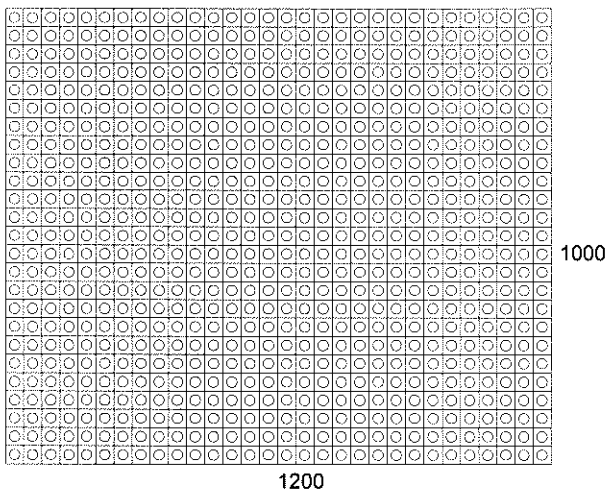

Notes: Asezare pe tava: 30X25=750 buc, 7 randuri, 5250 buc/palet; tavi carton: 1200x1000x60 mm, capac tava carton 1200x1000x60 mm; H palet= 1.18 m, G palet= 768 kg (masa butelie = 140 g); folie 2250 pliu mare.

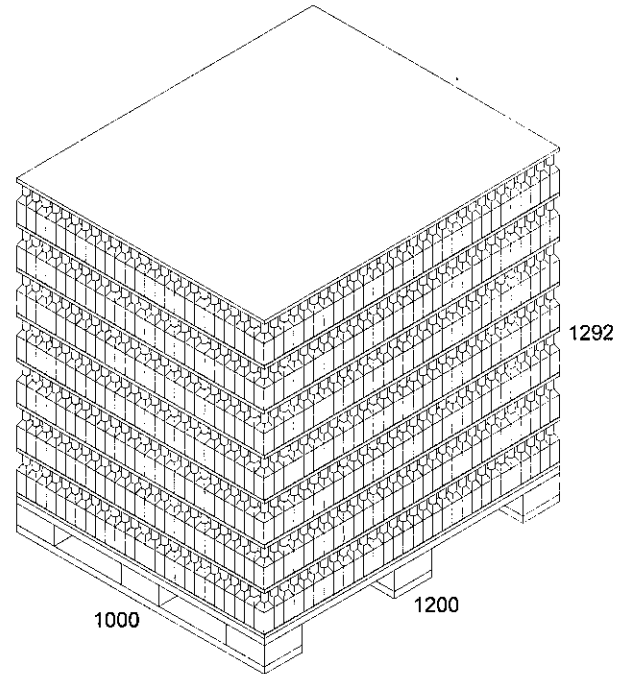
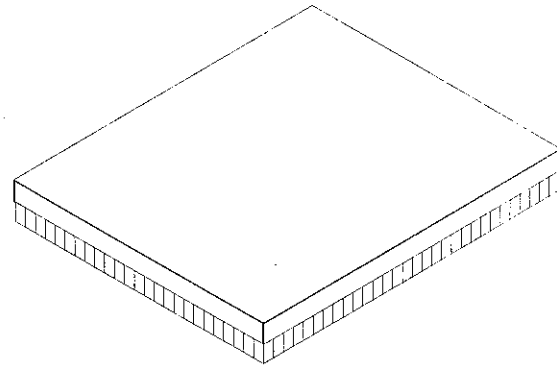
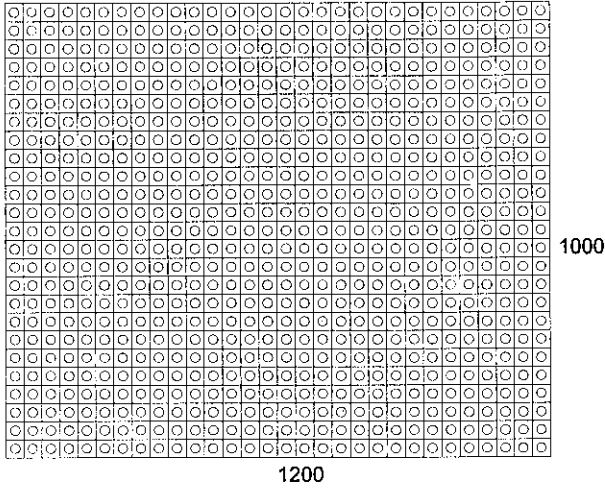

**GMA (Metric-Block) 1200x1000x125**

	Bottle (ID)	Bottle (OD)	UnitLoad (Incl. Pal)
Ln:	40.00 mm	40.00 mm	1200 mm
Wd:	40.00 mm	40.00 mm	1000 mm
Ht:	144.00 mm	144.00 mm	1292 mm
Net:		120.00 g	720.000 kg
Grs:		0.00 g	25.000 kg
Cube:	0.160 l	0.2 l	1.5507 m3

Height Vert

Bottle:	6000
Area Efficiency:	100.00 %
Cubic Efficiency:	42.64 %
Cases per layer:	750
Layers/load:	8
Pattern:	Column

Notes: Asezare pe separator: 30x25=750 buc, 8 randuri, 6000 buc/palet; separator plastic: 1200x1000 mm, capac tava carton 1200x1000x100 mm; H palet= 1.30 m, G palet=760 kg (masa butelie = 120 g); folie rola pliu mare.