

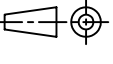

NAME	DATE	REVISIONS	MOLD NO.	1044	 A3  DRUJBA Glassworks S.A. A Member of Yioula Group		
B.D.	08.02	CAP.BRIMF. was 766±10ml	FINISH	FIN-086			
			CAP. BRIMF.	766+10ml	MACHINE	DG 5 1/2"	BOTTLE BORDEAUX ESTATE
			CAP. FILLPT.	750+10ml	DATE	09/12/2005	
			FILL LINE	75mm	DRAWN	HRISTOVA	CAT.No & DWG No 1044086
			WEIGHT	500g	CHECKED	DIMITROV	
			PROCESS	BB	CONFIRMED	H.PIK	SHEET:1/1 SCALE:1:1



DRUJBA PALLET 09 1200x1000x134

	Bottle (ID)	Bottle (OD)	UnitLoad (Incl. Pal)
Ln:	71.90 mm	71.90 mm	1200 mm
Wd:	71.90 mm	71.90 mm	1000 mm
Ht:	330.00 mm	330.00 mm	2129 mm
Net:		500.00 g	744.000 kg
Grs:		0.00 g	22.000 kg
Cube:	1.206 l	1.2 l	2.5550 m3

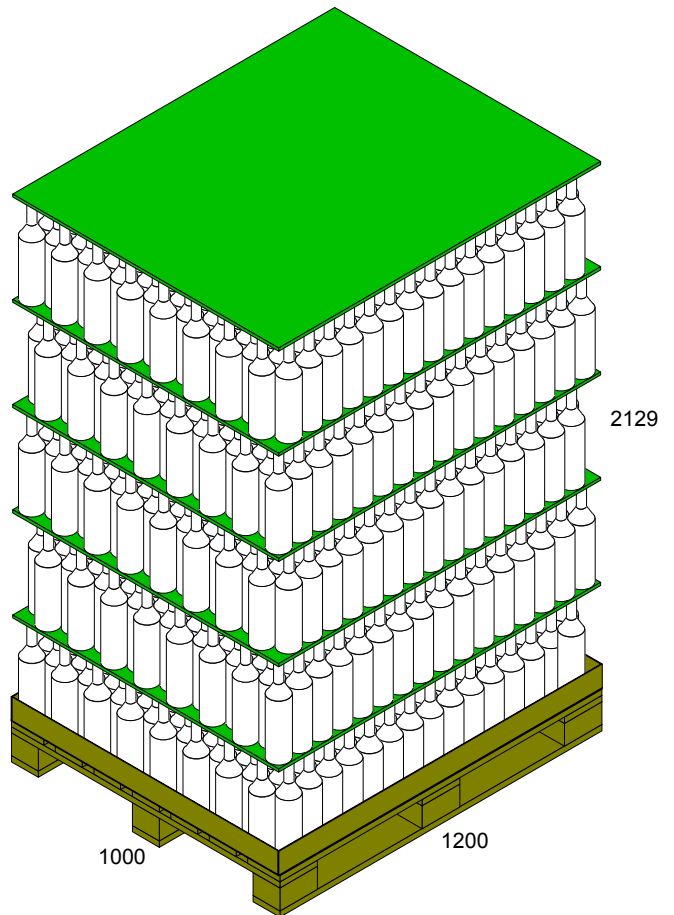
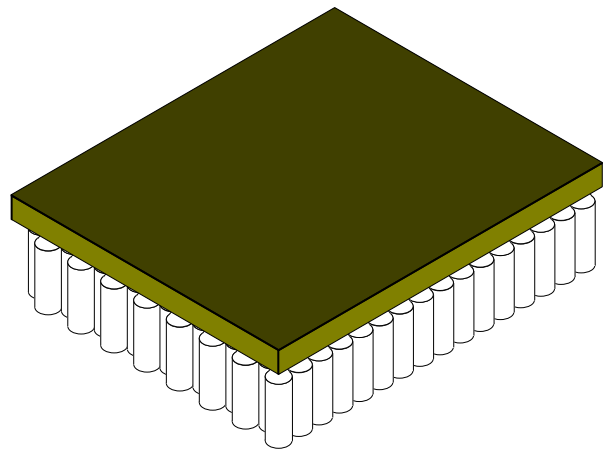
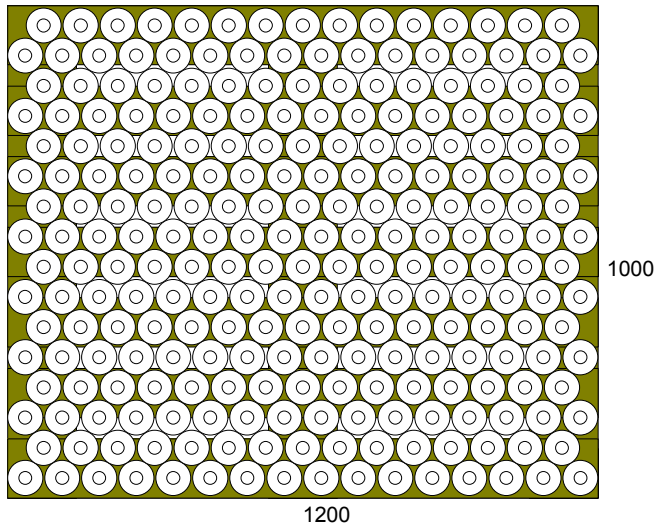
Height Vert

Bottle:	1488
Area Efficiency:	106.84 %
Cubic Efficiency:	72.41 %
Cases per layer:	248
Layers/load:	6
Pattern:	Staggered

Notes: THE WOODEN PALLET IN USE IS SPECIALLY FUMIGATED