

NAME	DATE	REVISIONS	MOLD NO.	1004	 DRUJBA S.A., STIND unit A Member of Yioula Group			
			FINISH	FIN-01	MACHINE		DG 5 1/2"	BOTTLE :
			CAP. BRIMF	770 \pm 10ml	DATE	Nov.02.2004	BURGUNDY	
			CAP. FILLPT	750ml	DRAWN	DIMITROV	CAT. NO & DWG NO.	
			FILL LINE	55mm	CHECKED		100401	
			WEIGHT	420g	CONFIRMED	H.PIK	SHEET 1/1	SCALE 1:1
			COLOR					

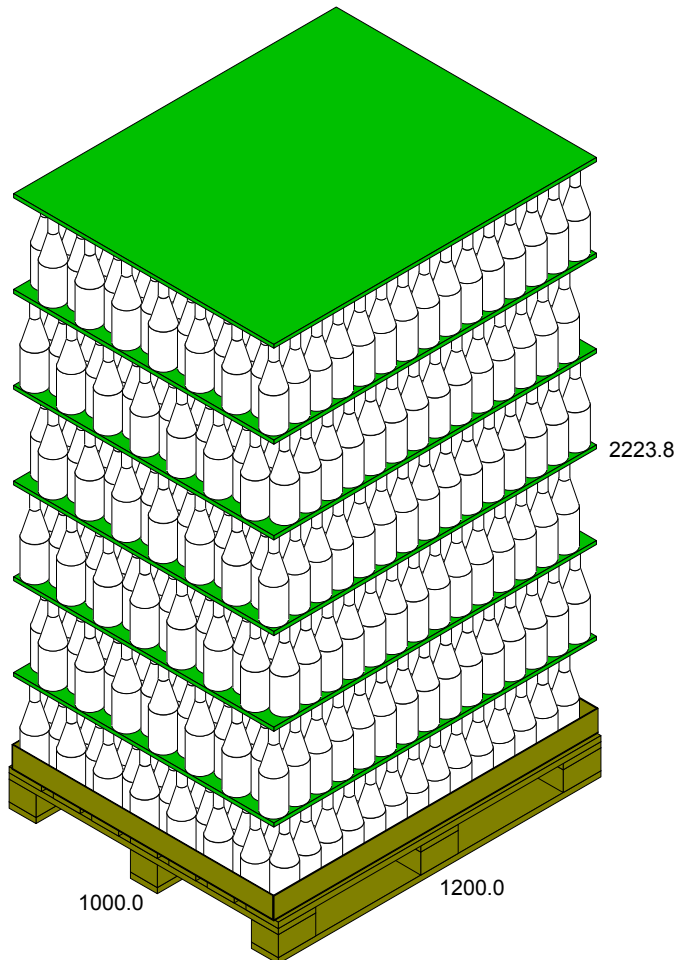
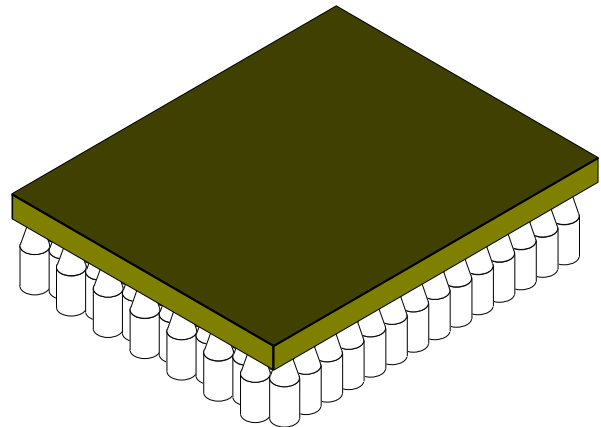
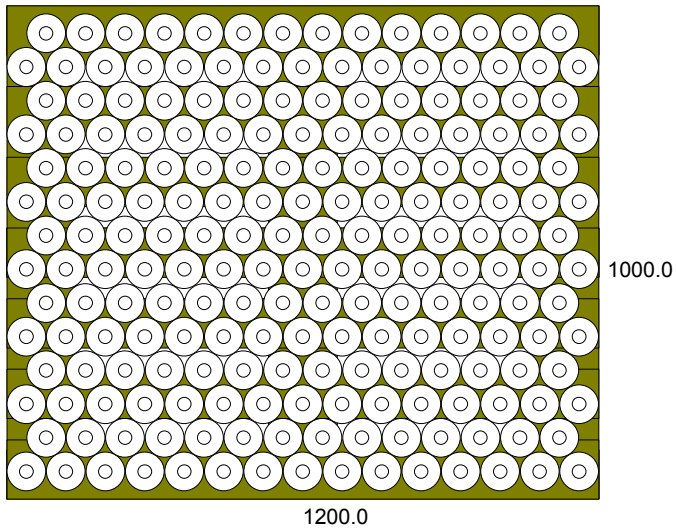

DRUJBA PALLET 09 1200.0x1000.0x134.0

	Bottle (ID)	Bottle (OD)	UnitLoad (Incl. Pal)
Ln:	79.20 mm	79.20 mm	1200.0 mm
Wd:	79.20 mm	79.20 mm	1000.0 mm
Ht:	296.00 mm	296.00 mm	2223.8 mm
Net:		420.00 g	596.820 kg
Grs:		0.00 g	22.000 kg
Cube:	1.107 l	1.1 l	2.6685 m3

Bottle: 1421
 Area Efficiency: 106.11 %
 Cubic Efficiency: 60.51 %
 Cases per layer: 203
 Layers/load: 7
 Pattern: Staggered

Notes: THE WOODEN PALLET IN USE IS SPECIALLY FUMIGATED