

26H180 CETIE GME 13.01

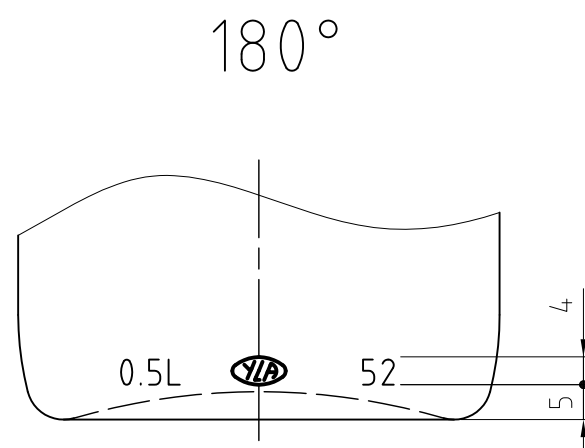

On the base of drawing 72770

NAME	DATE	REVISIONS	MOLD NO.			A3	DRUJBA Glassworks S.A. A Member of Yioula Group
			FINISH	FIN 020			
			CAP. BRIMF.	520 ± 7ml	MACHINE	DG 4 1/4"	BOTTLE
			CAP. FILLPT.	500 ± 7ml	DATE	30/01/2006	50 cl PLAKA
			FILL LINE		DRAWN	Stanchev	CAT.No & DWG No
			WEIGHT	295 ± 11.5gr	CHECKED	Angelov	1099020
			COLOR	FLINT	CONFIRMED		SHEET: 1/1 SCALE: 1:1

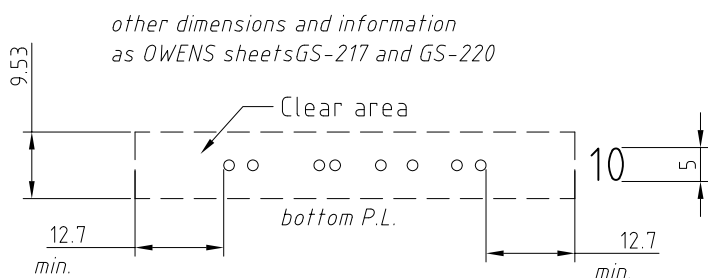
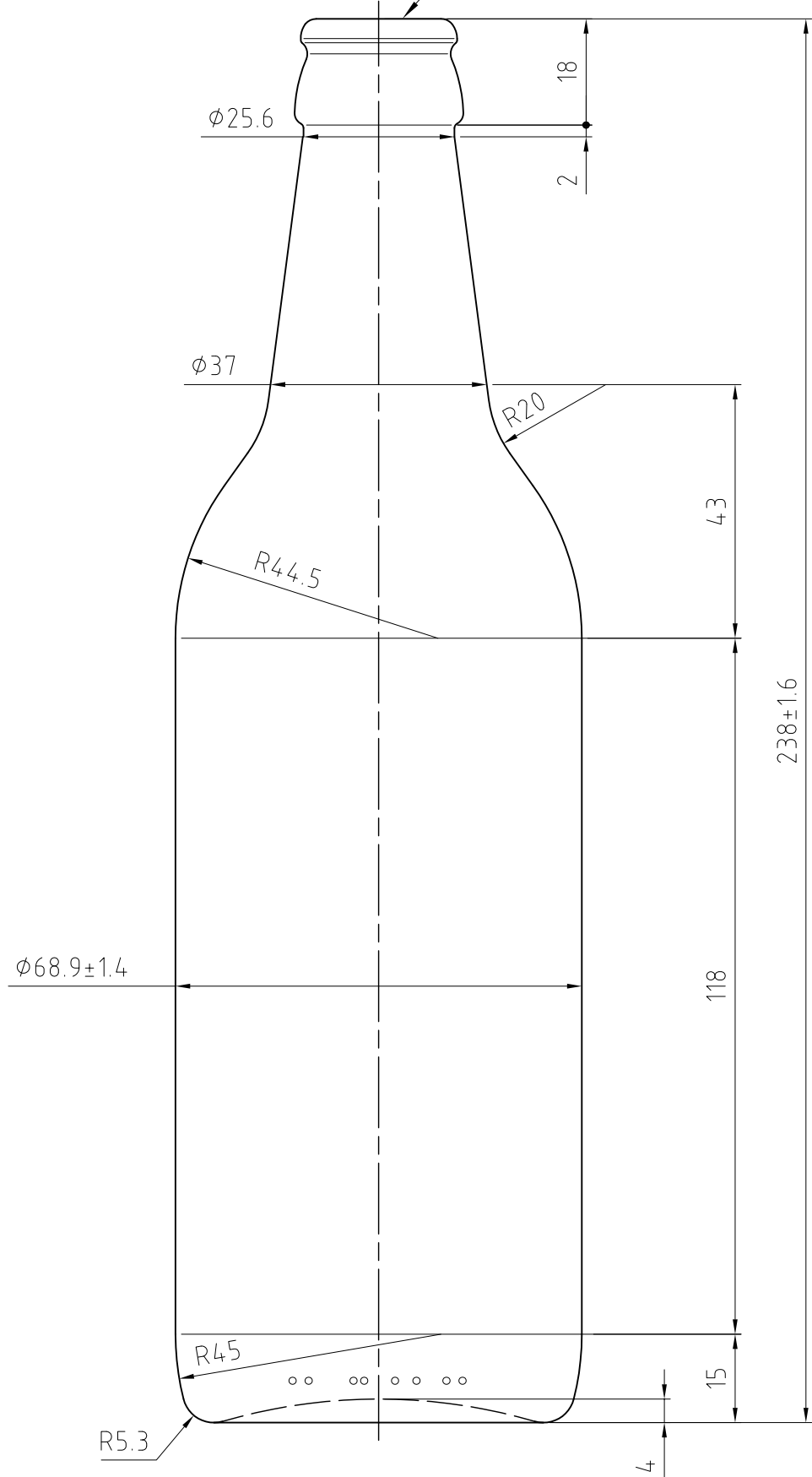
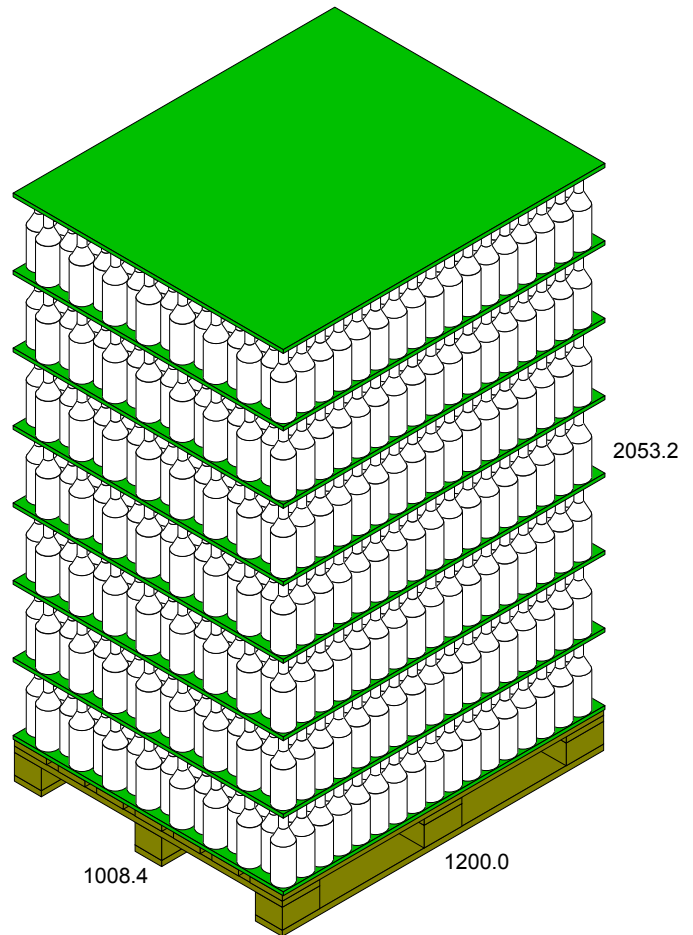
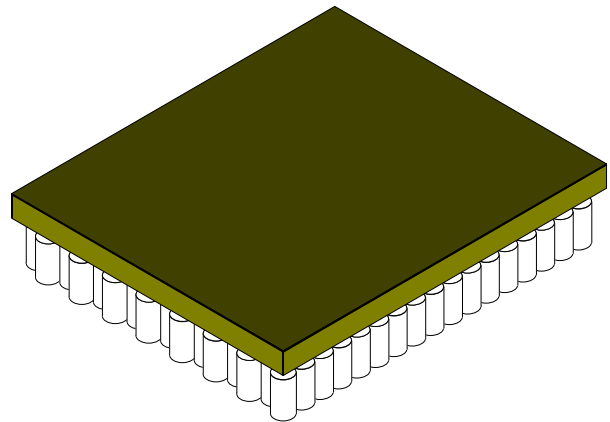
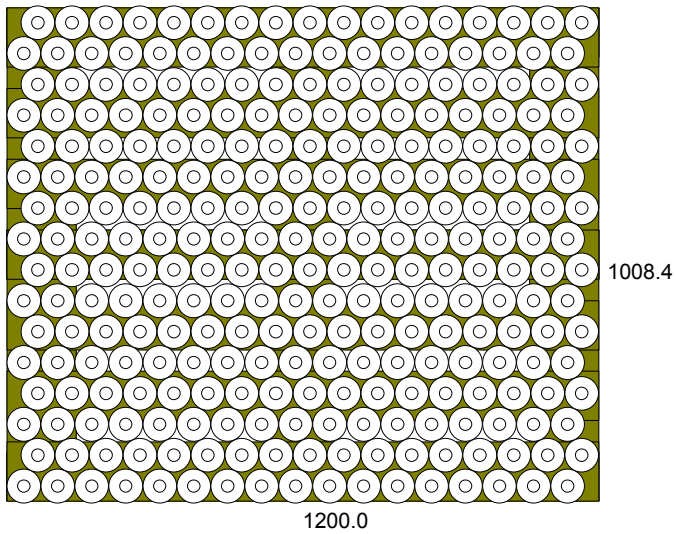

DRUJBA PALLET 09 1200.0x1000.0x134.0

	Bottle (ID)	Bottle (OD)	UnitLoad (Incl. Pal)
Ln:	68.90 mm	68.90 mm	1200.0 mm
Wd:	68.90 mm	68.90 mm	1008.4 mm
Ht:	238.00 mm	238.00 mm	2053.2 mm
Net:		295.00 g	641.920 kg
Grs:		0.00 g	22.000 kg
Cube:	0.756 l	0.8 l	2.4846 m3

Bottle: 2176
 Area Efficiency: 107.60 %
 Cubic Efficiency: 69.69 %
 Cases per layer: 272
 Layers/load: 8
 Pattern: Staggered

Notes: THE WOODEN PALLET IN USE IS SPECIALLY FUMIGATED