

DETAIL A
SCALE 2:1

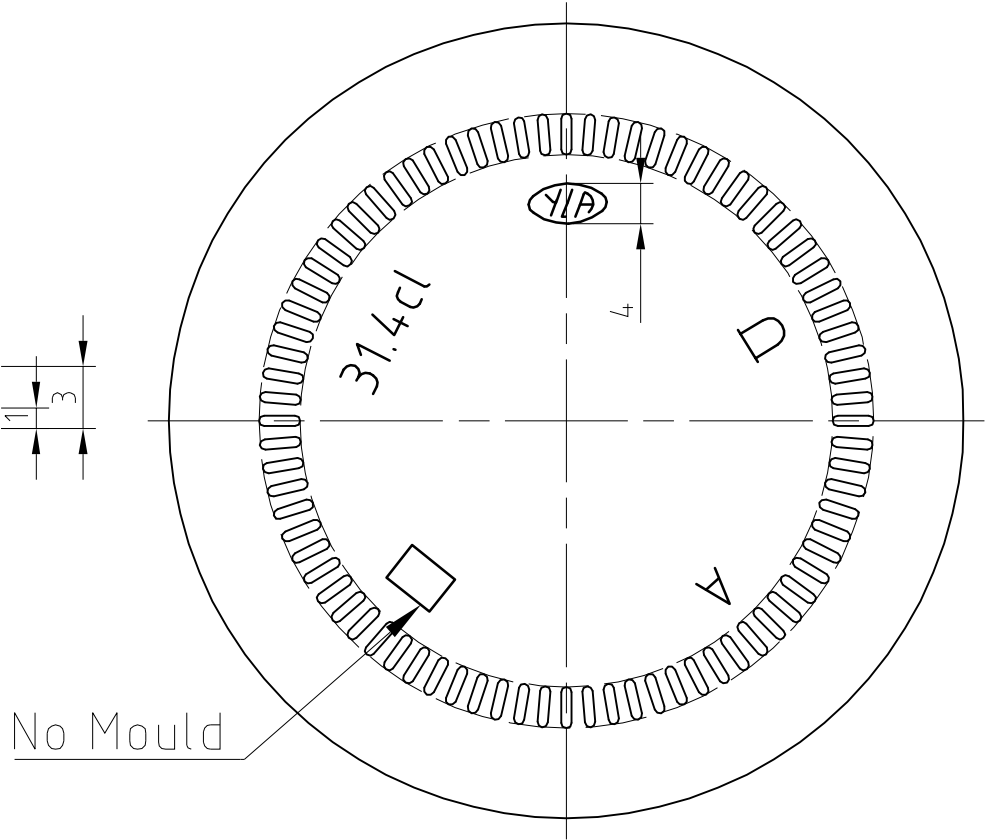

TO 70 REGULAR

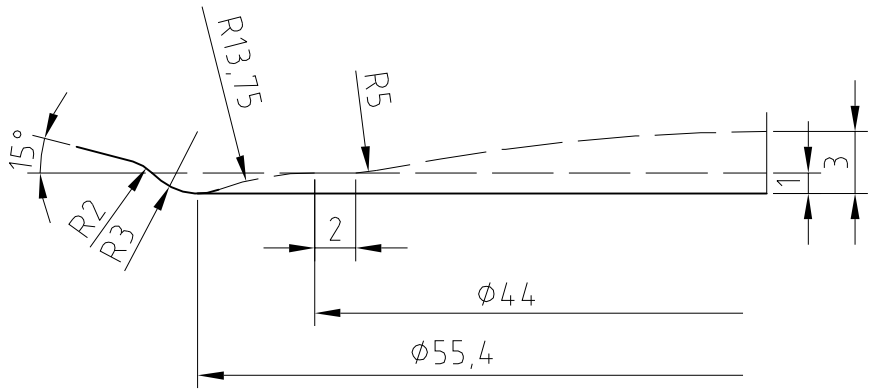
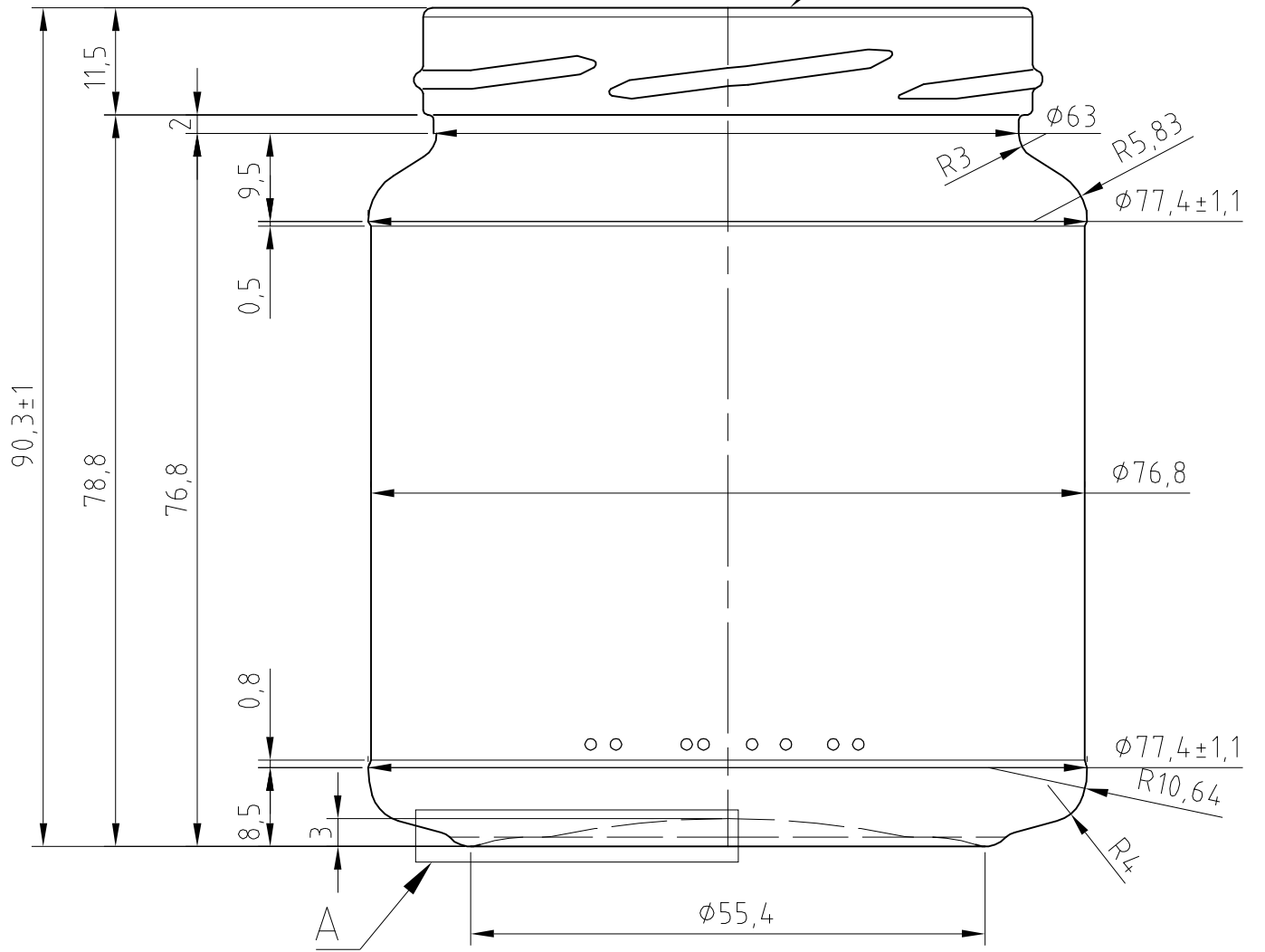

other dimensions and information
as OWENS sheets GS-217 and GS-220

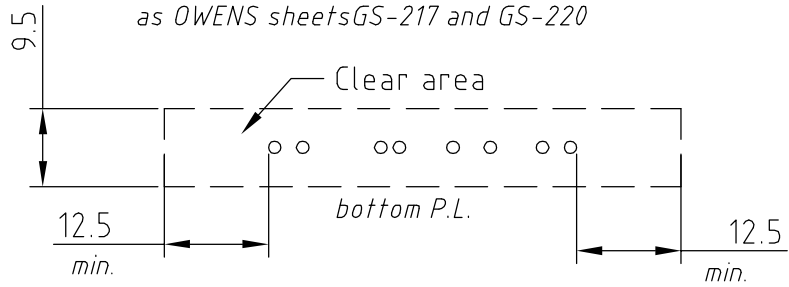

NAME	DATE	REVISIONS	MOLD NO.		A3	DRUJBA Glassworks S.A. A Member of Yioula Group	
			FINISH	FIN 718		BOTTLE	
			CAP. BRIMF.	314 ± 6ml	MACHINE	31.4cl VASO AMERICA	
			CAP. FILLPT.		DATE	15/06/09	CAT.No & DWG No
			FILL LINE		DRAWN	Dimov	8508718
			WEIGHT	180gr	CHECKED	Angelov	
			COLOR	FLINT	CONFIRMED		SHEET: 1/1 SCALE: 1:1



JARS

31.4CLVASO AMERICA C8508718-2

Date Printed : 21/10/2010

Last Saved : 21/10/2010

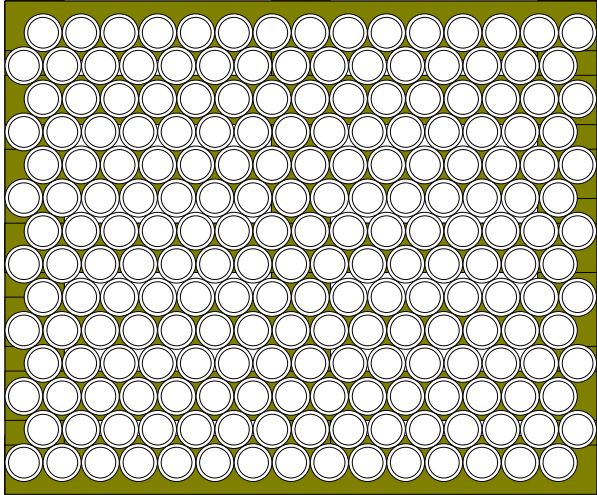

1200.0

1000.0

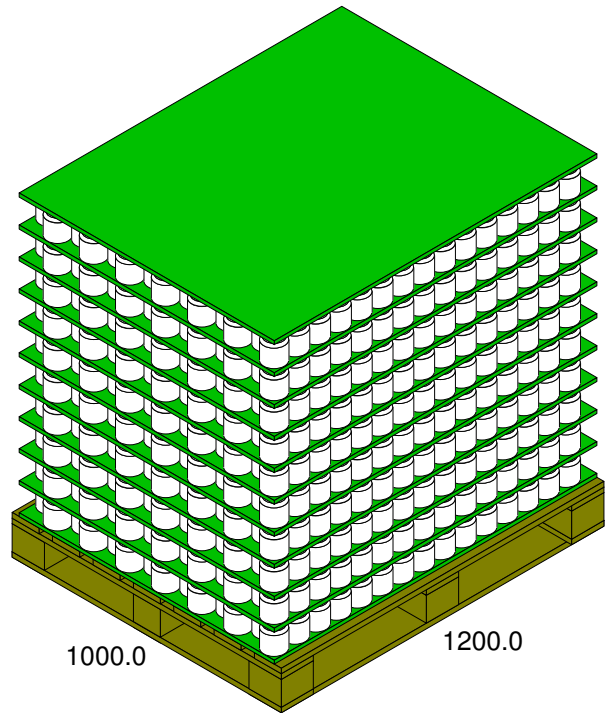
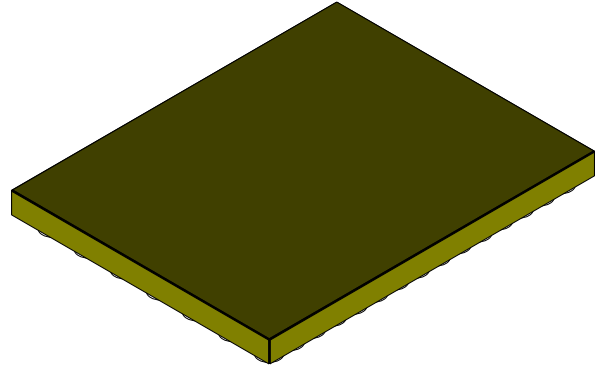

1156.3

1000.0

1200.0

FRENCH PALLET 1200.0x1000.0x144.0

	Bottle (ID)	Bottle (OD)	UnitLoad (Incl. Pal)
Ln:	77.40 mm	77.40 mm	1200.0 mm
Wd:	77.40 mm	77.40 mm	1000.0 mm
Ht:	90.30 mm	90.30 mm	1156.3 mm
Grs:		180.00 g	437.8 kg
Cube:	0.40 l	0.40 l	1.4 m3
		Height Vert	
Prod.Vol:	0.00 l		0.00 m3
Bottle:			2310
Area Efficiency:			104.8 %
Cubic Efficiency:			72.0 %
Prod.Eff:	0.0 %	0.0 %	0.0 %
Cases per layer:			210
Layers/load:			11
Pattern:			Staggered
Max UL High:			4
Clamp Direction:			N/A

Notes: THE WOODEN PALLET IN USE IS SPECIALLY FUMIGATED