

Conform desen MD 0366 A
Obs. - Cond. generale conform SF 675 / 1

NAME	DATE	REVISIONS	MOLD No:	220.00.649		A4		YOULA Glassworks
			FINISH No:	220.00.070				Stirom Romania
			PROCESS	BB	MACHINE	DG 4 1/4	BOTTLE:	DORICA 0.1 L
			TYPE	NRGB	TIP ANGLE	-		
			CAP. BRIMF.	110 ml	REF MOLD:	-	CAT.No & DWG No:	
			CAP. FILLPT	100±3ml	FINISH:	24 STD	00684	
			FILL LINE	~43 mm	DRAWN	SAW F.		
			WEIGHT	~100 g	CHECKED	GHENGEAUA F.	DATE	26.11.2010
			COLOR	FLINT	CONFIRMED	CONSTANTINESCU S.	SHEET: 1/1	SCALE: 1:1

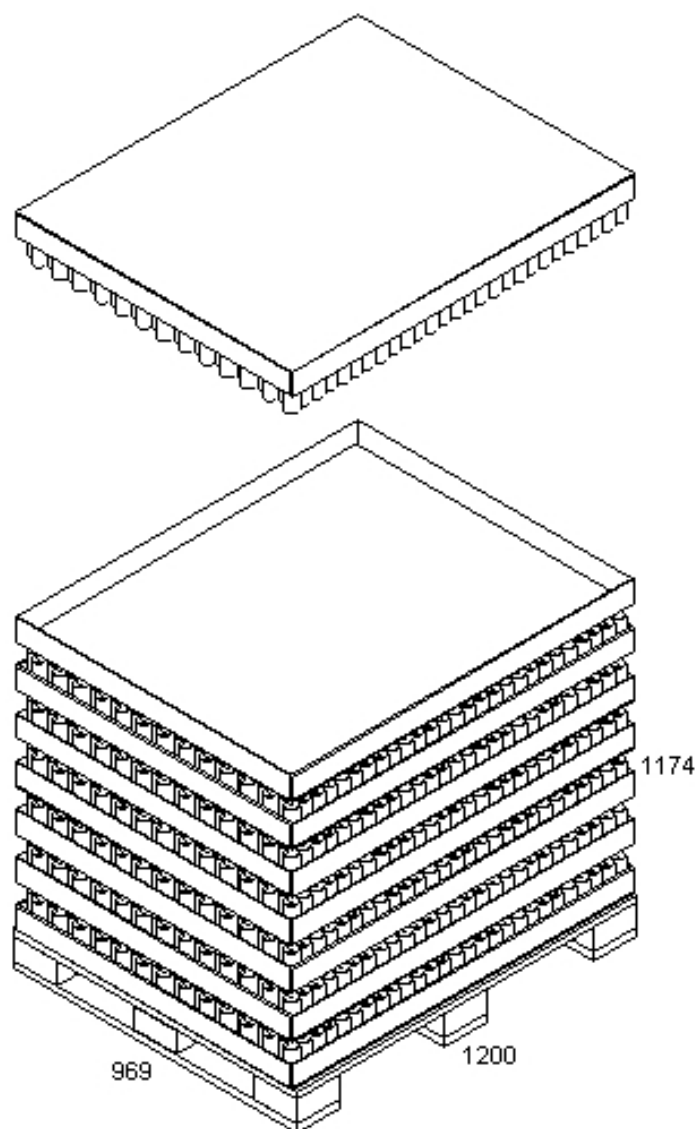

Notes: Asezare pe tava: $27 \times 13 + 26 \times 13 = 689$ buc, 7 randuri, 4823 buc/palet; tavi carton: 1200x1000x60 mm, capac tava carton 1200x1000x60 mm; H palet = 1.18 m, G palet = 757 kg (masa butelie=150g); folie 2250 pliu mare

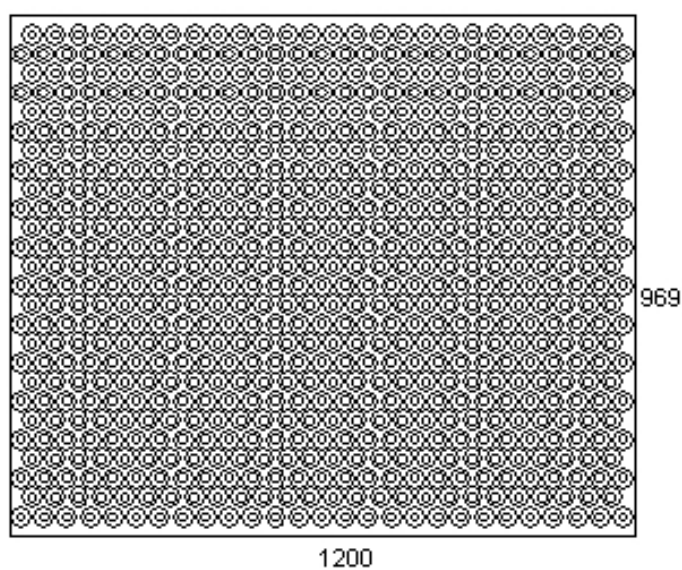
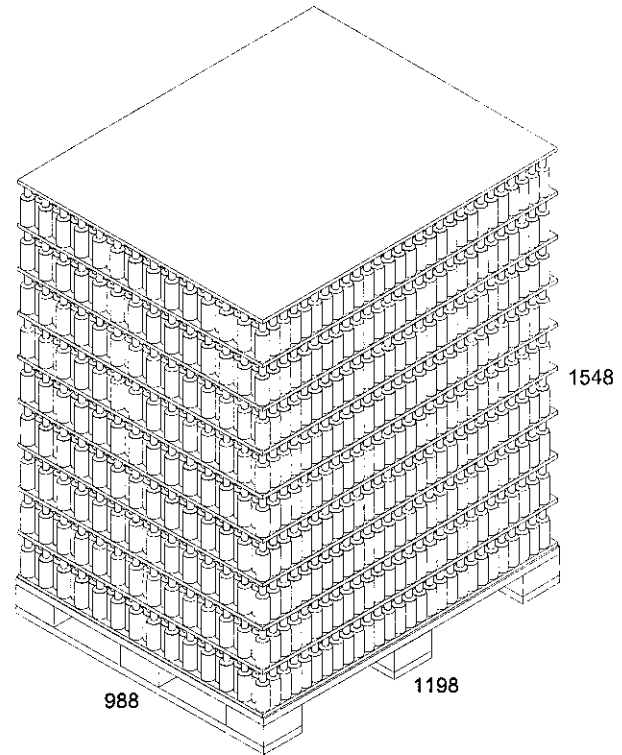
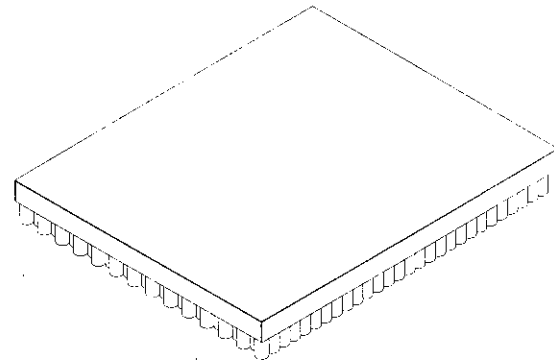
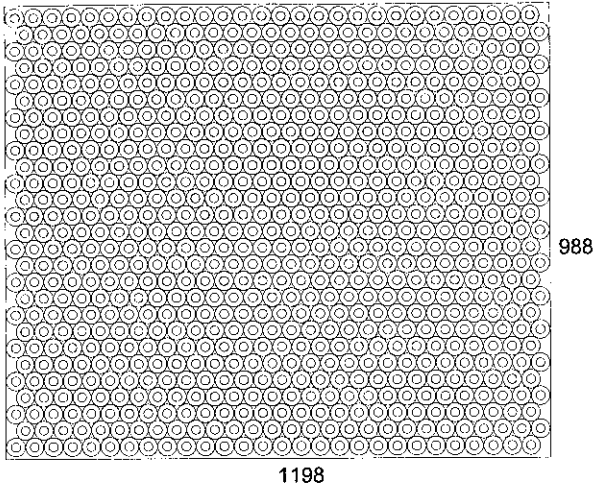

GMA (Metric-Block) 1200x1000x125

	Bottle (ID)	Bottle (OD)	UnitLoad (Incl. Pal)
Ln:	42.03 mm	42.03 mm	1198 mm
Wd:	42.03 mm	42.03 mm	988 mm
Ht:	140.50 mm	140.50 mm	1548 mm
Net:		100.00 g	756.000 kg
Grs:		0.00 g	25.000 kg
Cube:	0.182 l	0.2 l	1.8325 m3

Height Vert

Bottle:	7560
Area Efficiency:	111.29 %
Cubic Efficiency:	61.15 %
Cases per layer:	756
Layers/load:	10
Pattern:	Staggered

Notes: Asezare pe separator: 28x27=756 buc, 10 randuri, 7560 buc/palet; separator plastic 1200x1000 mm, capac tava carton 1200x1000x100 mm; H palet = 1.6 m, G palet = 798 kg (masa butelie=100g); folie rola pliu mare