

Other dimensions and information as
DOWNS sheets GS-217 and GS-220

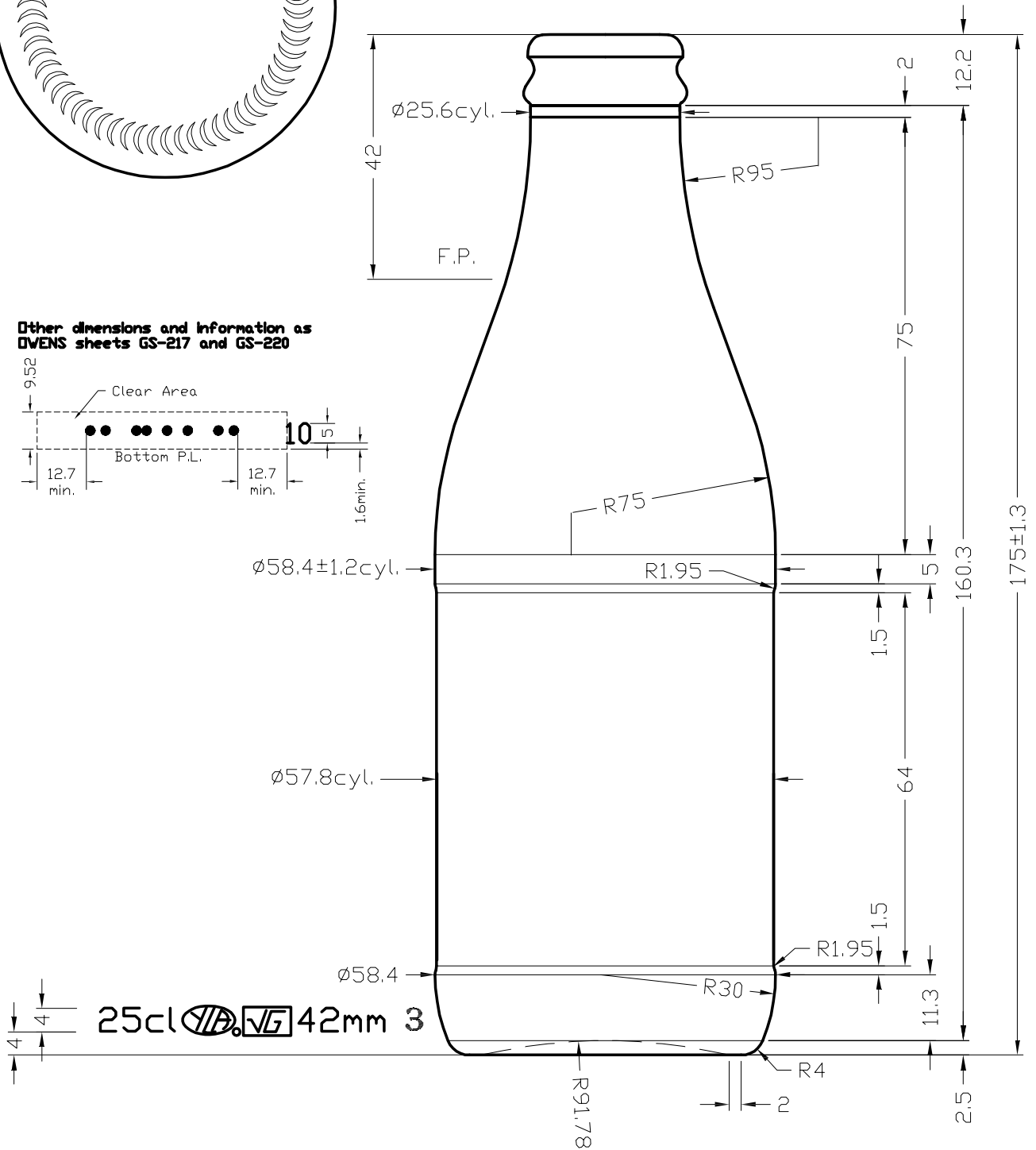
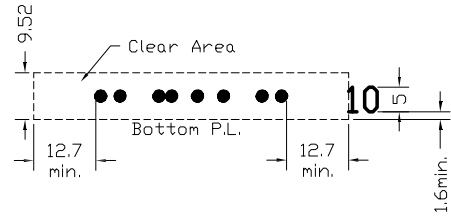

25cl 42mm 3

* Conform desen 72262

NAME	DATE	REVISIONS	MOLD No:	72262		A3		YIOULA Glassworks	
			FINISH No:	220.00.630				Stirom Romania	
			PROCESS	BB	MACHINE	DG 4 1/4	BOTTLE:	KLIAFAS 0.25 L	
			TYPE	NRB	TIP ANGLE	-			
			CAP. BRMF:	265 ml	REF MOLD:	-		CAT.No & DWG No:	
			CAP. FILLPT:	250±4ml	FINISH:	26 H 126 GME 13.02		00710	
			FILL LINE	~42mm	DRAWN	SAVU F.			
			WEIGHT	185±8g	CHECKED	GHENGEAUA F.		DATE	24.03.2011
			COLOR	FLINT	CONFIRMED	CONSTANINESCU S.		SHEET: 1/1	SCALE: 1:1

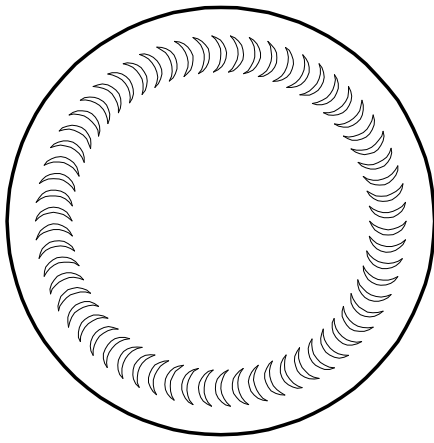

Other dimensions and information as
DWENS sheets GS-217 and GS-220

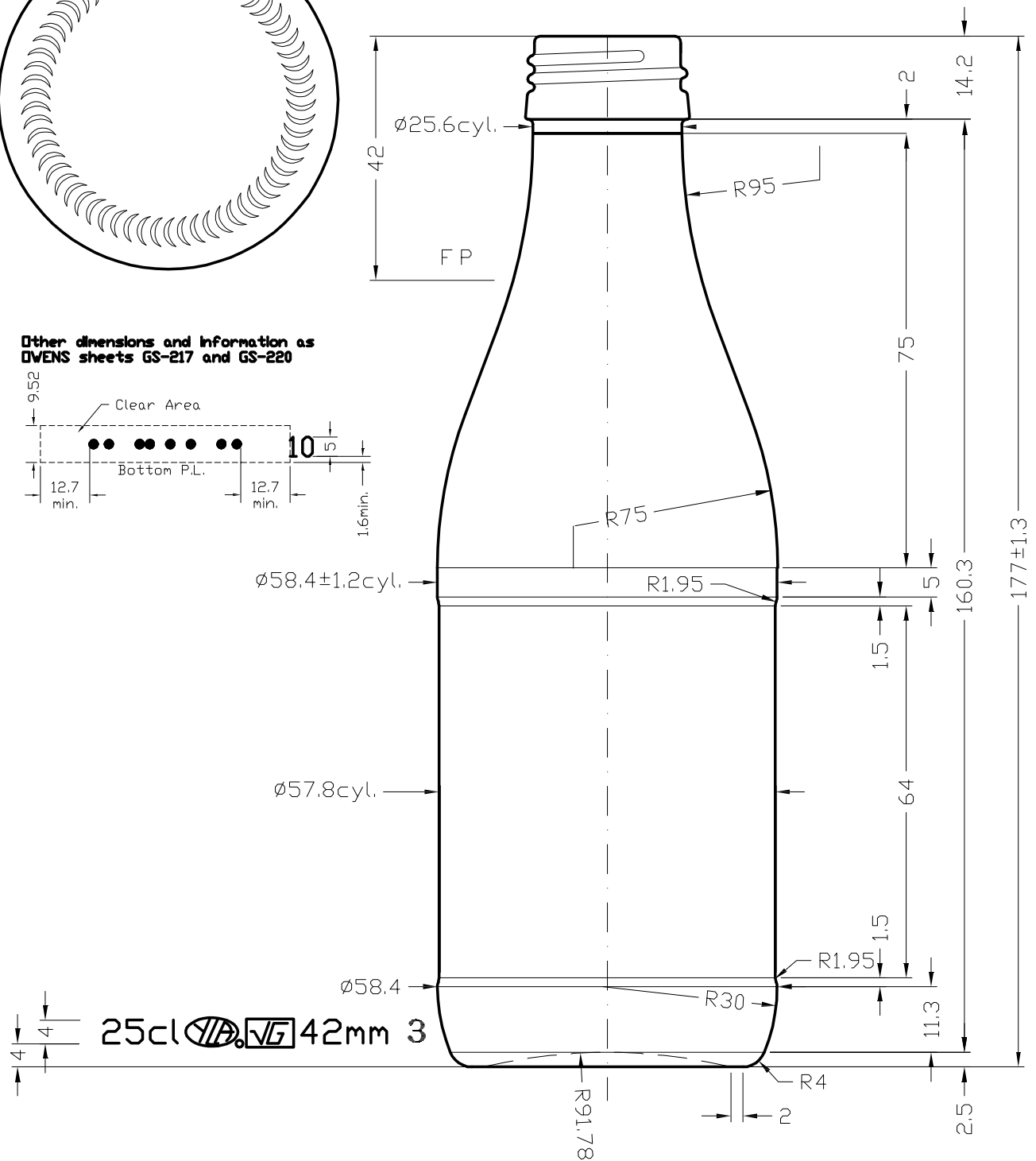
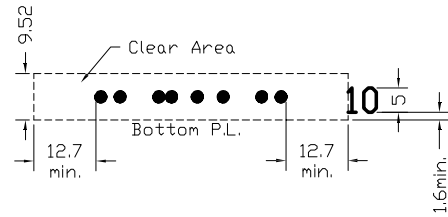

* Conform desen 72362

NAME	DATE	REVISIONS	MOLD No:	72262		A3		YIOULA Glassworks	
			FINISH No:	MCA 1				Stirom Romania	
			PROCESS	BB	MACHINE	DG 4 1/4	BOTTLE:		
			TYPE	NRB	TIP ANGLE	-	KLIAFAS 0.25 L		
			CAP. BRIMF.	263.7 ml	REF MOLD:	-	CAT.No & DWG No:		
			CAP. FILLPT.	250±4ml	FINISH:	MCA 1 (8G)	00713		
			FILL LINE	~42mm	DRAWN	SAVU F.			
			WEIGHT	190±8g	CHECKED	GHENGEAUA F.	DATE	31.03.2011	
			COLOR	FLINT	CONFIRMED	CONSTANTINESCU S.	SHEET: 1/1	SCALE: 1:1	

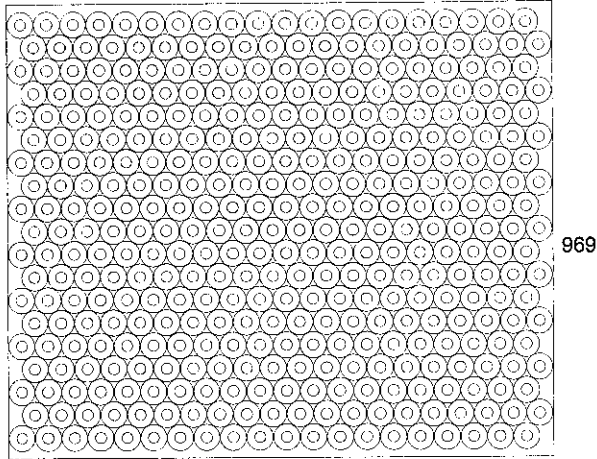

1197

GMA (Metric-Block) 1200x1000x125

	Bottle (ID)	Bottle (OD)	UnitLoad (Incl. Pal)
Ln:	58.40 mm	58.40 mm	1197 mm
Wd:	58.40 mm	58.40 mm	969 mm
Ht:	177.00 mm	177.00 mm	1021 mm
Net:		190.00 g	361.000 kg
Grs:		0.00 g	25.000 kg
Cube:	0.424 l	0.4 l	1.1847 m3

Height Vert

Bottle:	1900
Area Efficiency:	108.00 %
Cubic Efficiency:	35.80 %
Cases per layer:	380
Layers/load:	5
Pattern:	Staggered

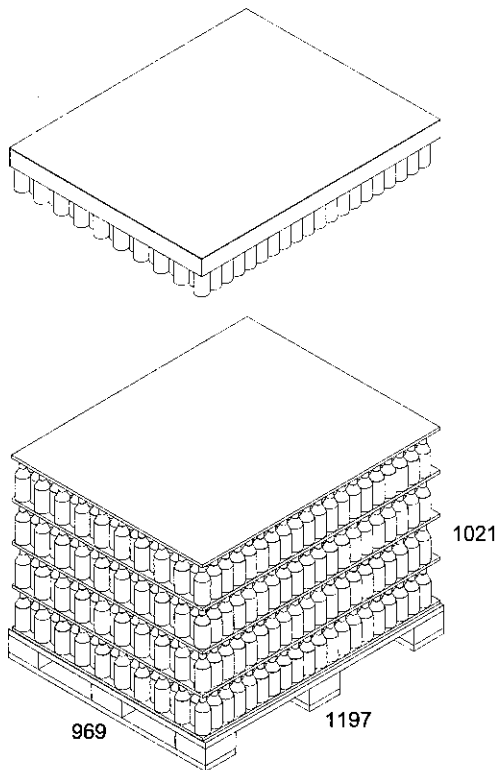

969

1197

1021

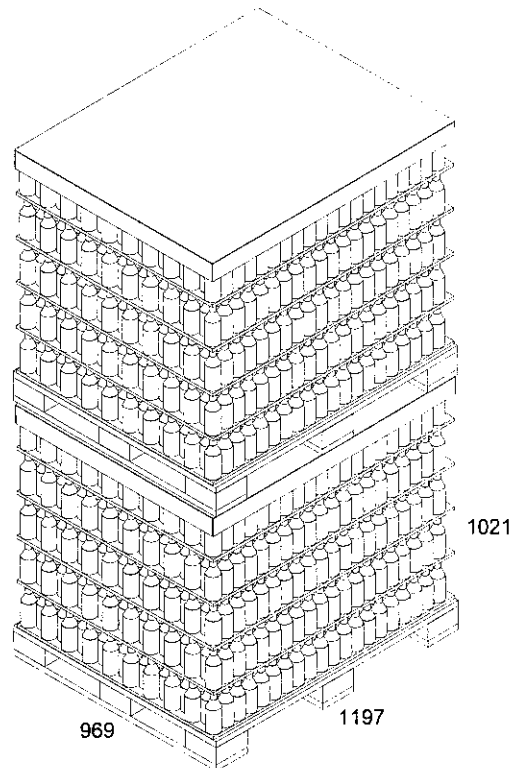

969

1197

1021

Notes: Asezare pe separator 20x19=380 buc, 5 rinduri, 1900 buc/palet, separator plastic 1200x1000 mm, capac tava carton 1200x1000x100 mm, H palet = 1.03 m, G palet = 396 kg (masa butelie =190 g), folie rola pliu mare