

PP 28S DIN 6094

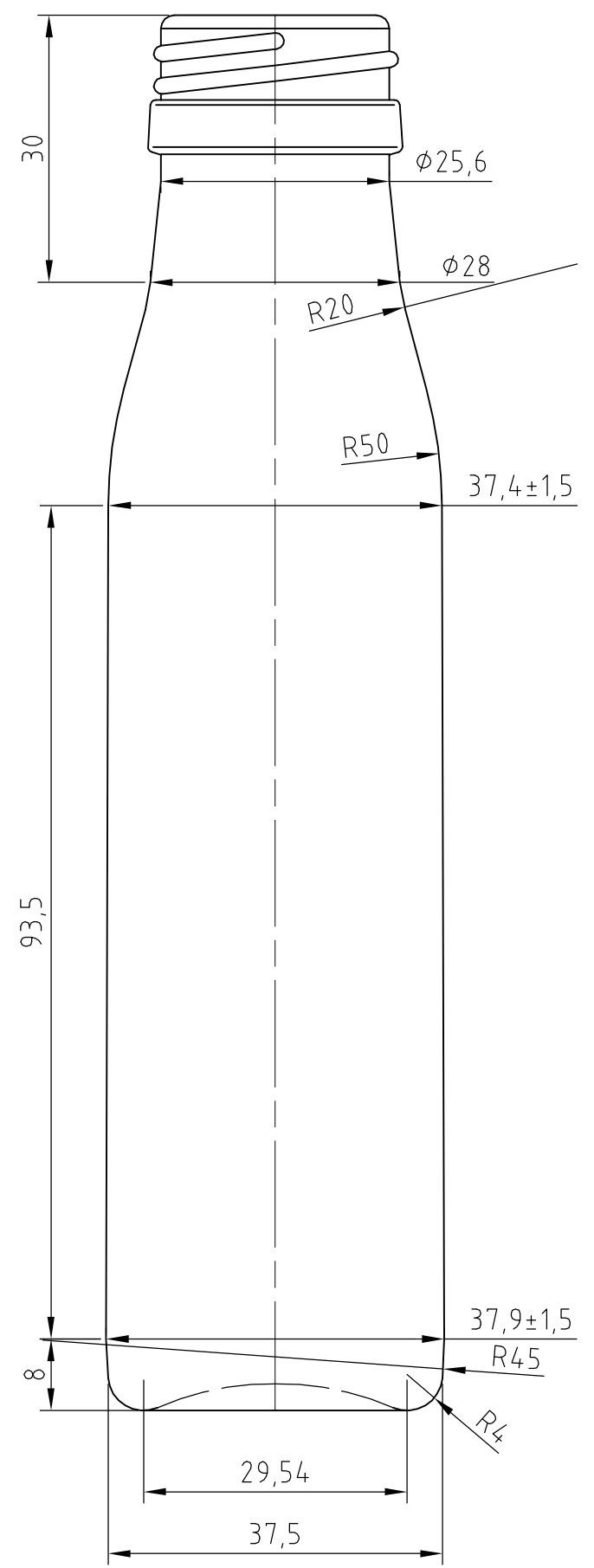

On the base of drawing 00204 STIROM

| NAME | DATE | REVISIONS | MOLD NO.     |         | A3        | DRUJBA Glassworks S.A.<br>A Member of Yioula Group |                            |
|------|------|-----------|--------------|---------|-----------|--|----------------------------|
|      |      |           | FINISH       | FIN031  |           | BOTTLE   |                            |
|      |      |           | CAP. BRIMF.  | 213     | MACHINE   | 20cl GIN   |                            |
|      |      |           | CAP. FILLPT. | 200±6ml | DATE      | 26/05/2009   | CAT.No & DWG No<br>3075031 |
|      |      |           | FILL LINE    | 37mm    | DRAWN     | Dimov  |                            |
|      |      |           | WEIGHT       | 210gr   | CHECKED   | Angelov  | SHEET: 1/1   SCALE: 1:1    |
|      |      |           | COLOR        |         | CONFIRMED |  |                            |

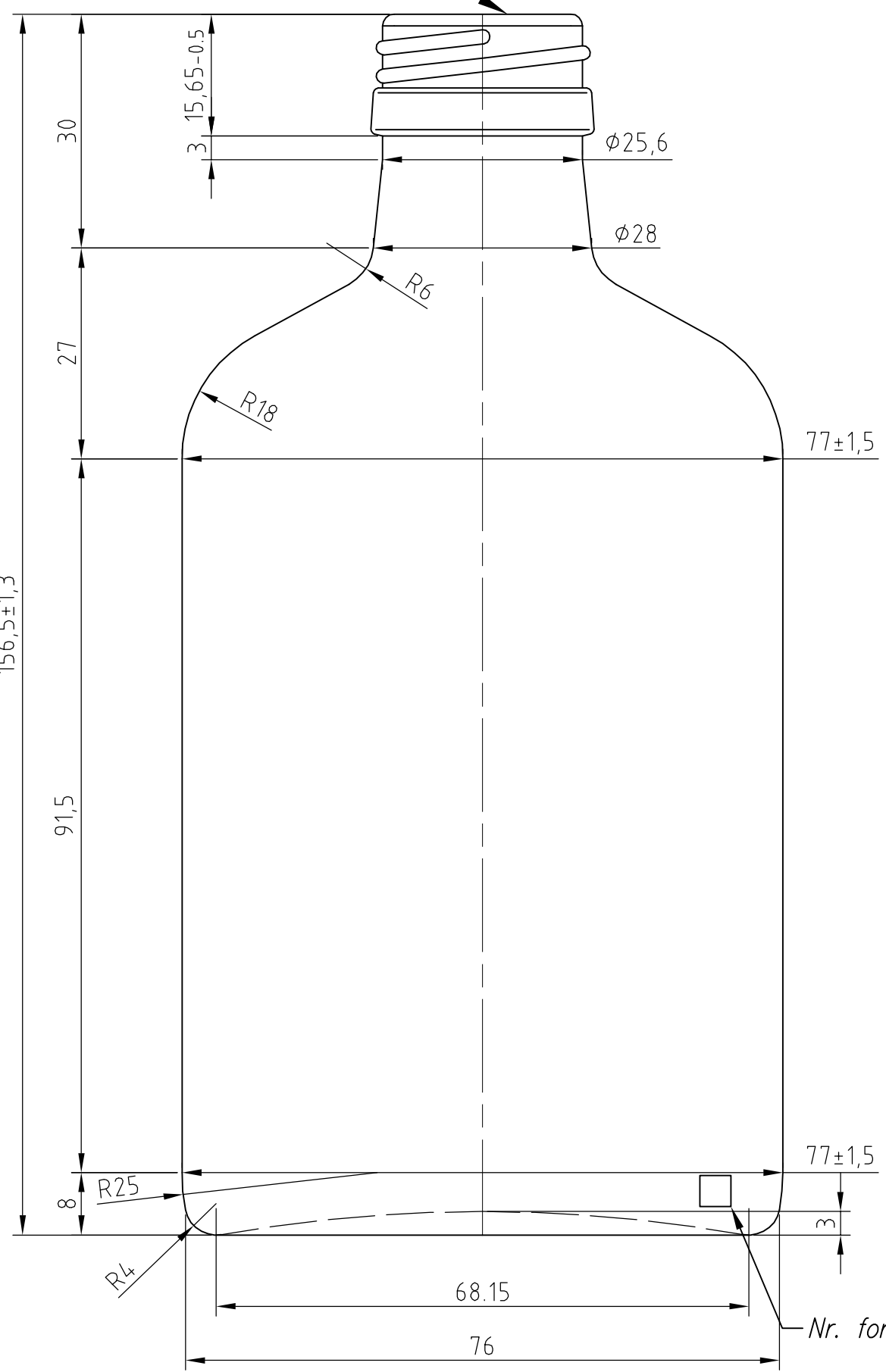
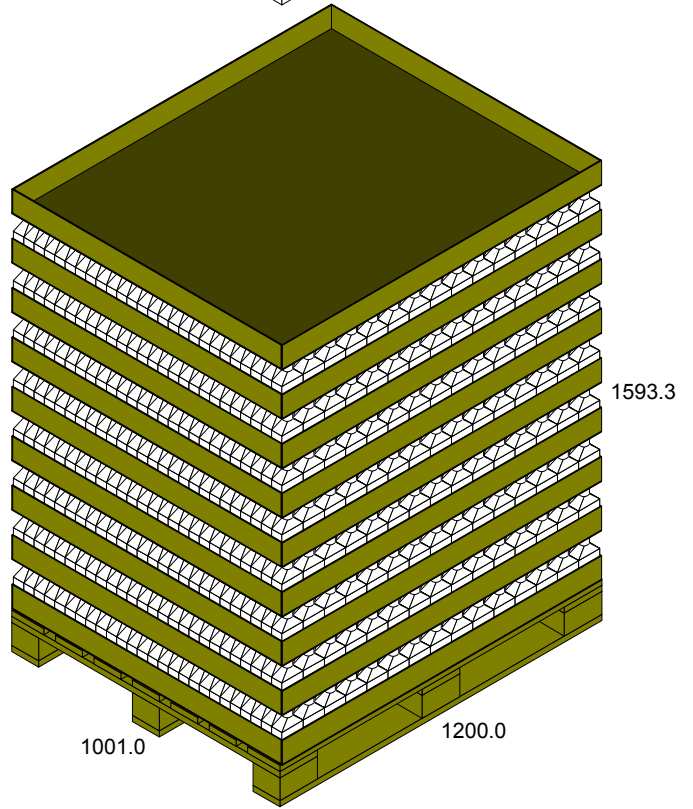
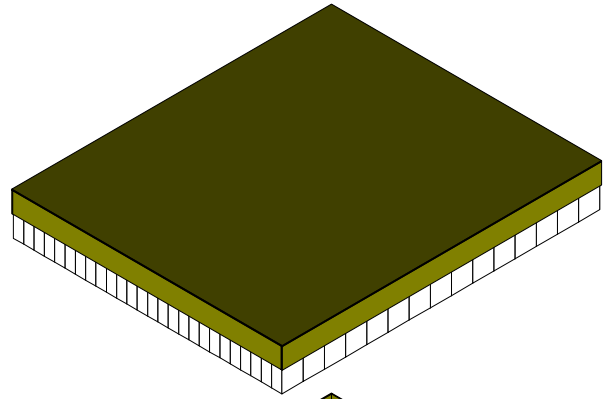
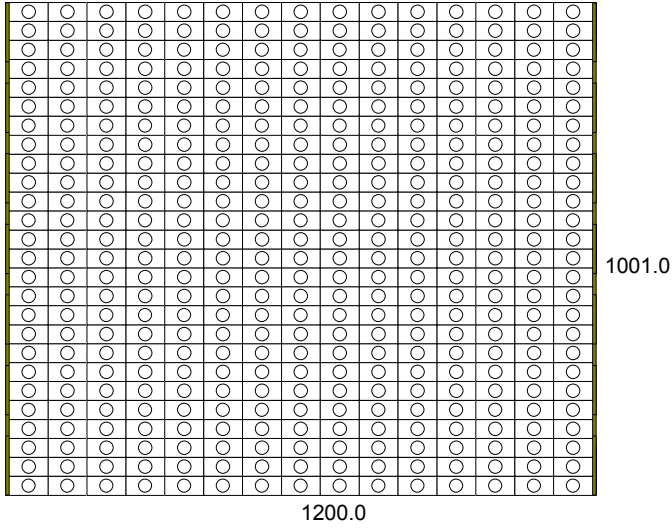

**DRUJBA PALLET 09 1200.0x1000.0x134.0**

|       | Bottle (ID) | Bottle (OD) | UnitLoad (Incl. Pal) |
|-------|-------------|-------------|----------------------|
| Ln:   | 79.00 mm    | 79.00 mm    | 1200.0 mm            |
| Wd:   | 38.50 mm    | 38.50 mm    | 1001.0 mm            |
| Ht:   | 156.50 mm   | 156.50 mm   | 1593.3 mm            |
| Net:  |             | 220.00 g    | 772.200 kg           |
| Grs:  |             | 0.00 g      | 22.000 kg            |
| Cube: | 0.367 l     | 0.4 l       | 1.9139 m3            |

Height Vert

|                   |         |
|-------------------|---------|
| Bottle:           | 3510    |
| Area Efficiency:  | 98.85 % |
| Cubic Efficiency: | 73.25 % |
| Cases per layer:  | 390     |
| Layers/load:      | 9       |
| Pattern:          | Column  |

Notes: THE WOODEN PALLETS IN USE IS SPECIALLY FUMIGATED